



HANDLEBAR CATCH AND NIPPLE.

In 2003 Brompton introduced a new handlebar catch, which has to be used in conjunction with a new nipple. Both are supplied as part of the kit. The new catch is also fitted with a spring.

If you are replacing a handlebar catch of the earlier, pre-2003 type (these early ones are obviously different, as at right), then:-

- You should remove the old nipple and replace it with the new nipple – if you don't do this swap, the new catch will not be effective.
- Also, because the new catch is longer than formerly, the new nipple has to be screwed further onto the stud on the handlebar stem than the old nipple. If you don't do this, the handlebars will end up sticking out from the folded package (but see figs HB7 & HB8 below).
- Remember that when you do adjust the nipple, you should make sure that it ends up parallel to the catch, so that it enters true (figs HB5 & HB6 below).



Fitting a handlebar catch.

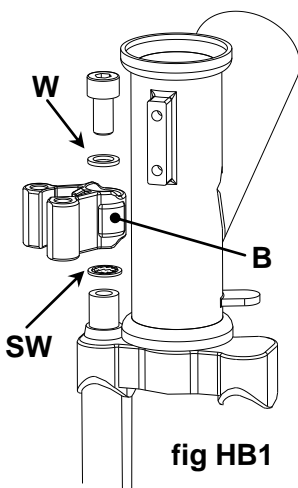

washer under the catch.

First decide which way up to fit the catch. There is a bulge, B, on the body of the catch: this should, on a 5-speed, be directed forwards and to the left (fig HB1), and, on any other bike, rearwards and to the right (fig HB2). It does not matter whether the spring is on the top or bottom.

Next, before assembly, make sure that the star washer, SW, is in place *under* the catch, and that the small washer W is under the head of the screw. The correct torque for the securing screw is 9NM.

On early superlight bikes with alloy headsets, a second star washer may have been fitted to ensure that the back of the catch does not rub on the lower bearing cup. On such bikes you should retain this second star

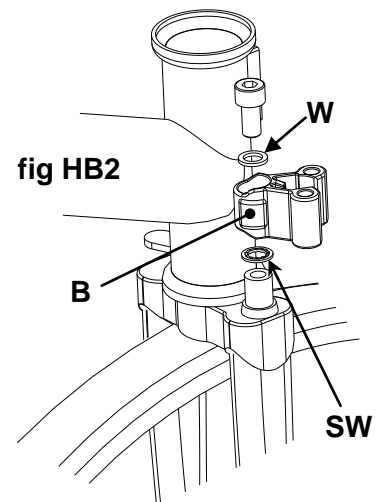

[Note. The bulge B determines the angle at which the front wheel lies relative to the folded package. If you find that, having fitted the catch with the bulge pointing aft, the front wheel is slightly loose (i.e. is still free to turn a bit when folded), you can improve things by bending out the left-hand side of the front mudguard stay, and/or by reversing the handlebar catch so that the bulge is pointing forward. Conversely, if the bulge is pointing forward, and if, as you hook the front wheel to the rear frame, things are a bit tight, then you can bend the LH side of the mudguard stay inwards a bit, or else reverse the handlebar catch.]

subtext hbcadj

Setting up the handlebar catch and nipple: if this is wrong, the handlebar catch will lose its spring effect, with the result that the handlebars can become unlatched too easily from the folded package.

- Alignment of the catch, HBC: the catch itself must be aligned so that the nipple enters centrally (fig HB3 rather than HB4).
- Alignment of the nipple, HBNIP: this should be in line with the catch HBC as it enters it during folding (fig HB5 rather than HB6). Bear this in mind if making adjustments as below.
- Offset of the nipple HBNIP: if the handlebar itself, or the control levers/cables, are set too far forward, they may, on folding, foul against the front wheel and so prevent the nipple from fully entering the catch (i.e. as per fig HB8). To remedy, either reset the handlebar or levers further back (i.e further out when folded), or unscrew the nipple so that it is further from the support tube, HBS: the nipple must be able to enter the catch HBC fully, as per fig HB7.

If the set-up is correct and the catch remains ineffective, either replace the h'bar catch, or you may obtain a temporary cure by twisting the nipple slightly (i.e. as not normally recommended, fig HB6).

fig HB3

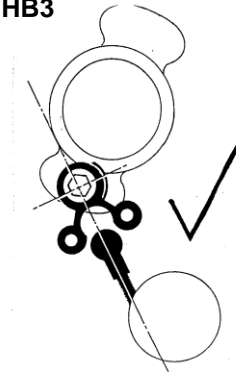

fig HB4

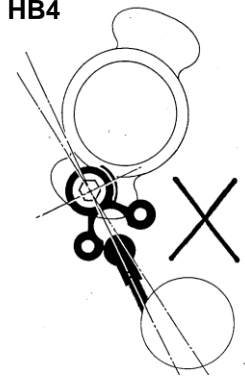

fig HB5

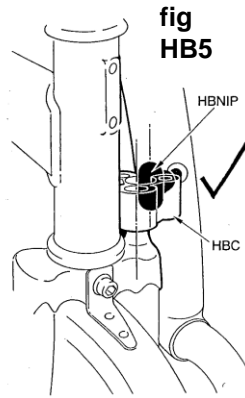

fig HB6

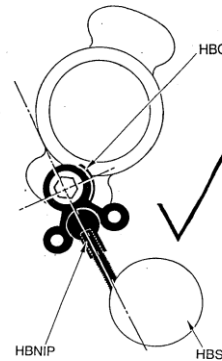
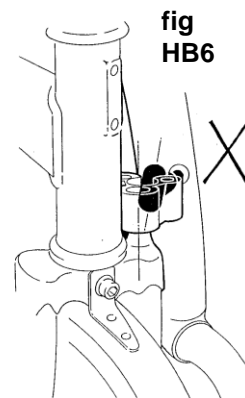

fig HB7

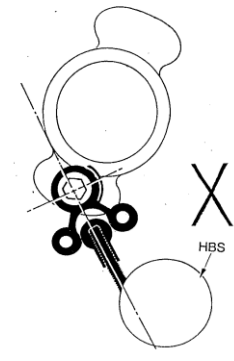

fig HB8