

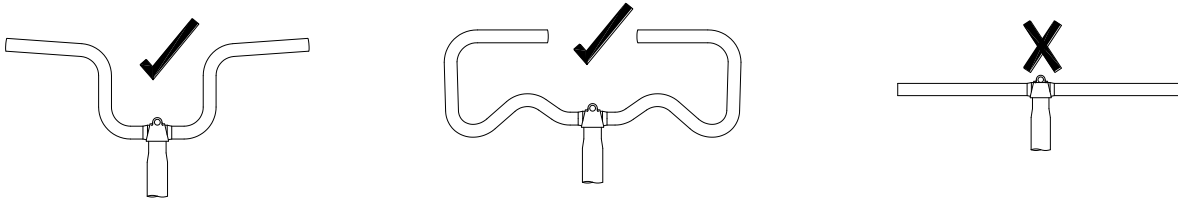

C Bag

This luggage item is NOT suitable for use with a Brompton S-type model.



It is **DANGEROUS** to use it on an S-type, as it interferes with the steering.

Stowing the shoulder strap

The C Bag comes fitted with a padded shoulder strap. This is designed to be stowed away when the bag is fitted to the bike so there is no risk of loose material snagging. To stow the strap open the cam buckle and pull the strap through so it is tight against the top of the bag. Close the buckle and stuff the loose loop of strap into the mesh stuff pocket.

For safe use it is essential that the strap is 'stowed' when the bag is fitted to the bike.



Removing the strap

If you prefer not to use the strap and would like to remove it from the bag it can be taken off. Unthread the strap from the buckle above the zipped pocket on the left hand side. Remove the pad, pull the strap all the way through the cam buckle and then unthread it from the buckle on the right hand side.

Re-fitting the strap

To refit the strap thread it through the buckle above the mesh pocket, pulling it through as far as it will go, as per fig CBAG1. Double it back through the buckle and thread it through the cam buckle as per fig CBAG2.

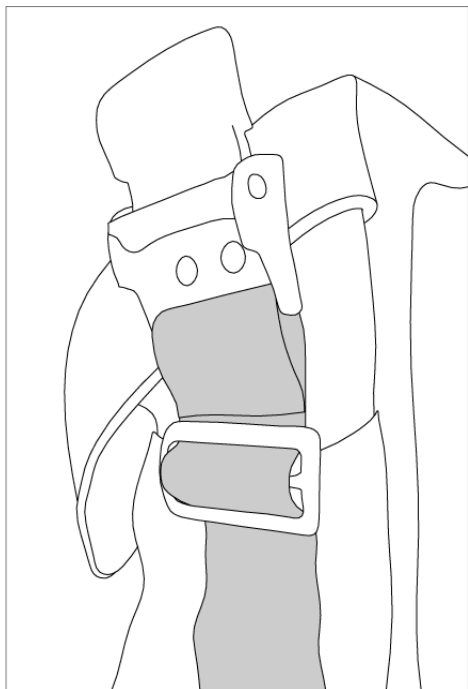

fig CBAG1

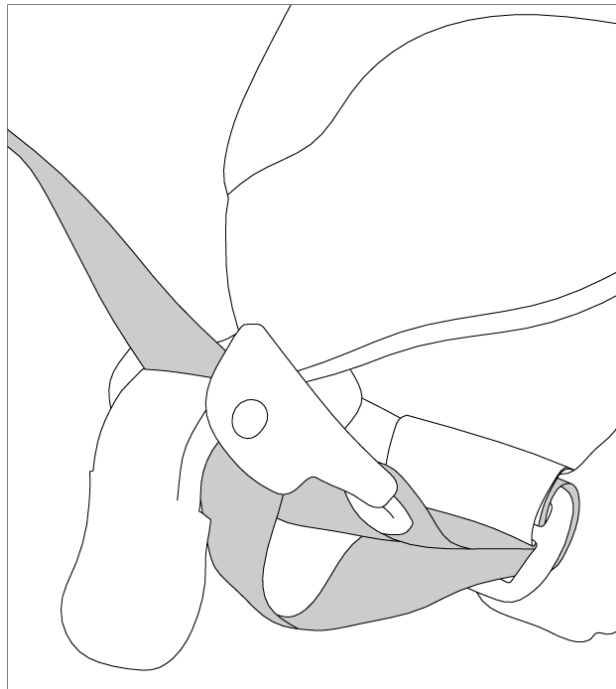

fig CBAG2

Thread the strap through the shoulder pad. End by threading the end of the strap through the buckle above the zipped pocket on the left hand side (fig CBA3), doubling it back as shown in fig CRBAG4

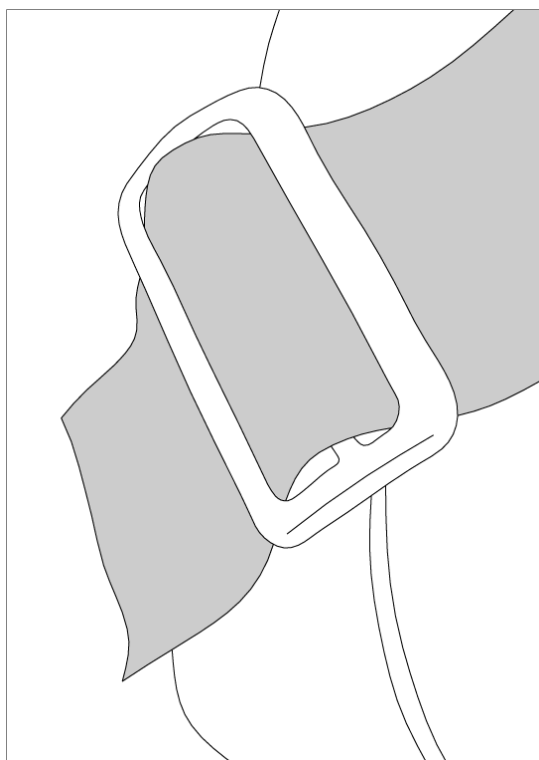

fig CBAG3

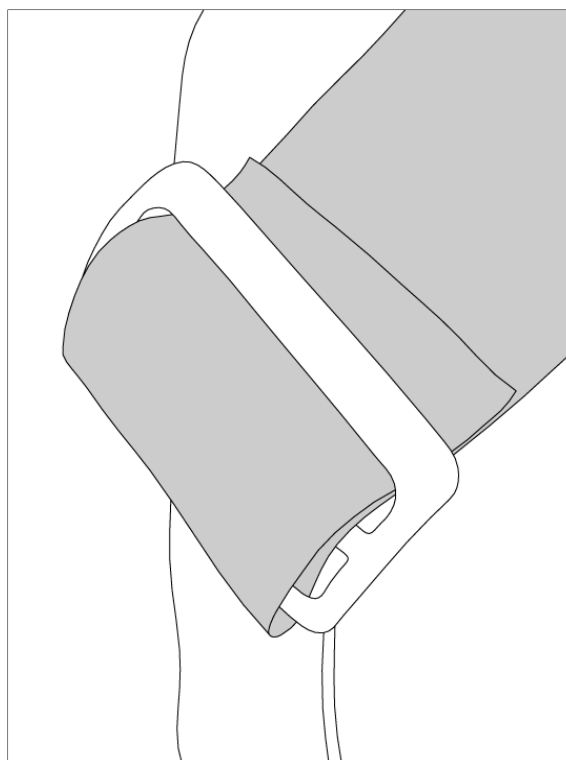

fig CBAG4